

Kawasaki

Assembly Instructions

Model:	EX250P/S/T/V/W/X, EX400G/H/J/K, ER250E, ER400D/E
Description:	Helmet Lock
Part Number:	99994-1037
Flat Rate Time(Hr):	EX250P/S/T/V/W/X, EX400G/H/J/K: 0.6 ER250E, ER400D/E: 0.5

Before you begin, read through these instructions and check that all parts are present. Please note that Kawasaki cannot assume any responsibility for damage resulting from incorrect installation.

Kawasaki recommends that all genuine accessories should be fitted by an authorized Kawasaki dealer.

The following symbols indicate the information for proper installation and operation in this instruction.

- Indicates a procedural step or work to be done.
- Indicates a procedural sub-step or how to do the work of the procedural step it follows. It also precedes the text of a NOTE.

Refer to the Service Manual for detailed procedures.

(EX250P/S) P/No.: 99924-1534-02

(EX250T/V) P/No.: 99924-1535-02

(EX250W/X) P/No.: 99924-1562-01

(EX400G/H/J) P/No.: 99924-1536-02

(EX400K) P/No.: 99924-1561-01

(ER250E) P/No.: 99924-1550-01

(ER400D/E) P/No.: 99924-1551-01 or 99967-0005-01

Parts List				
No.	Component Name	Part No.	Qty	Remark
1	Helmet Lock	27017-0023	1	
2	Bracket	39184-0725	1	
3	Pad	39156-2158	1	
4	Bolt	92154-2355	1	
5	Screw	92172-0835	1	

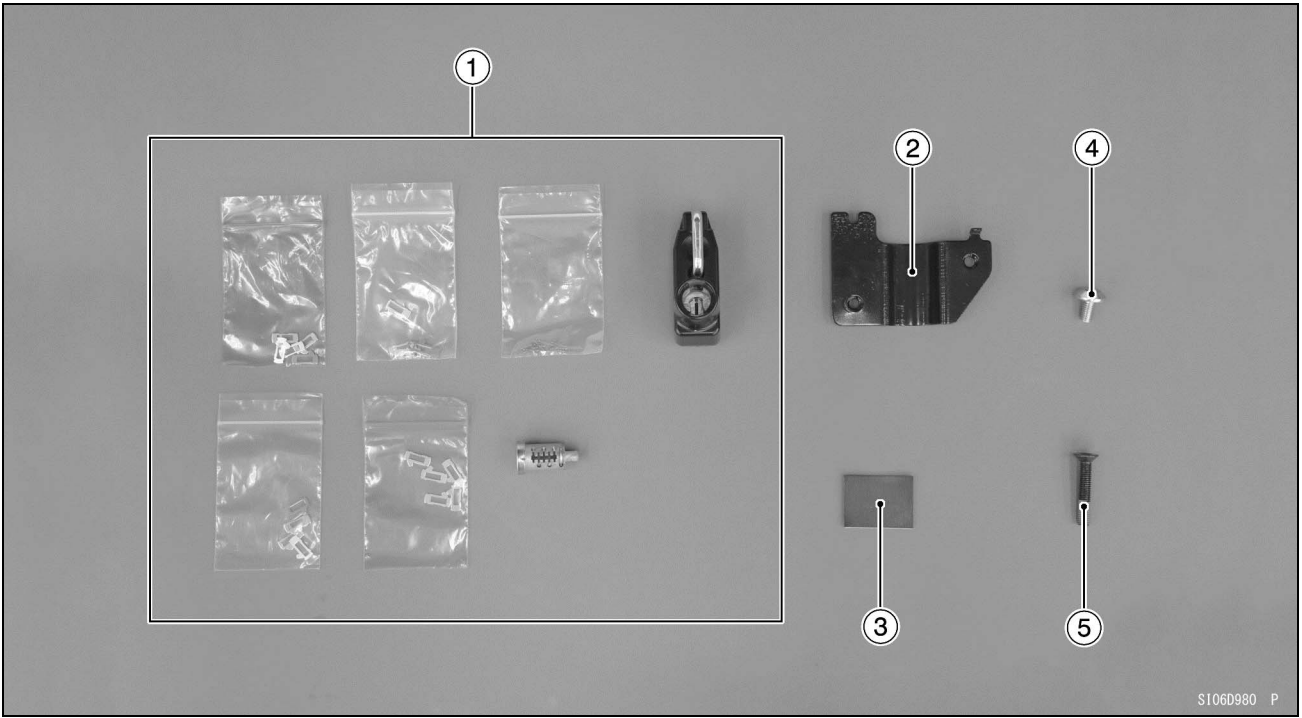

S106D980 P

Installation Instructions

Assembly Procedure (One Key System)

- Using a combination of tumblers allows the lock rotor to be assembled to fit the existing ignition key.
- The four kinds of tumblers are a different length [A] to each other as shown.

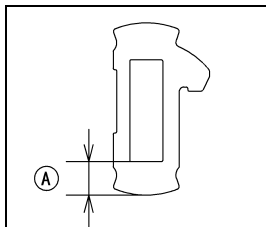

Tumbler #1: 2.5 mm (0.098 in.)

Tumbler #2: 3.0 mm (0.12 in.)

Tumbler #3: 3.5 mm (0.14 in.)

Tumbler #4: 4.0 mm (0.16 in.)

- The tumblers are separated into 4 plastic bags by different colors. Keep them in the bags until needed to prevent from being mixed up.

Step 1

- Install 5 springs [A] and 5 tumblers #1 [B] from a bag to the grooves [C] of the rotor [D]. Press each tumbler into its groove until it fully seats.

NOTE

- *The projection of the tumbler should sit over the spring.*

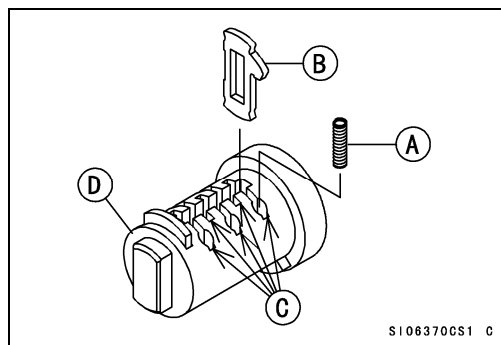

Step 2

- Lightly hold the tumblers [A] in the rotor [B] and insert the ignition key [C].

NOTE

- *If the tumblers are not held in place the tumblers or springs may become dislodged.*

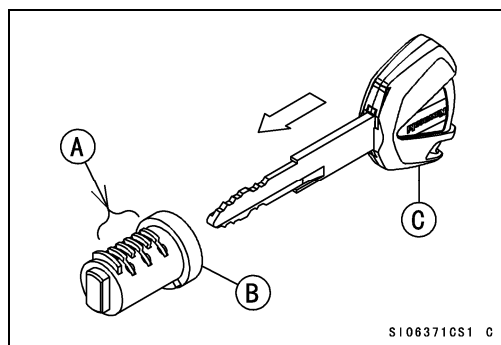

Step 3

- If the tumbler [A] is the correct one for the cut of the key, it will sit level with the rotor [1] once the ignition key [E] is inserted.
Incorrect: [B] Projecting high (upper or lower of rotor)
Incorrect: [C] Projecting low (upper or lower of rotor)
Correct: [D] Level with the rotor
- If any of the tumblers project out of the rotor, go to “Step 4.”
- If all tumblers sit flush with the rotor it is correct. Go to “Step 5.”

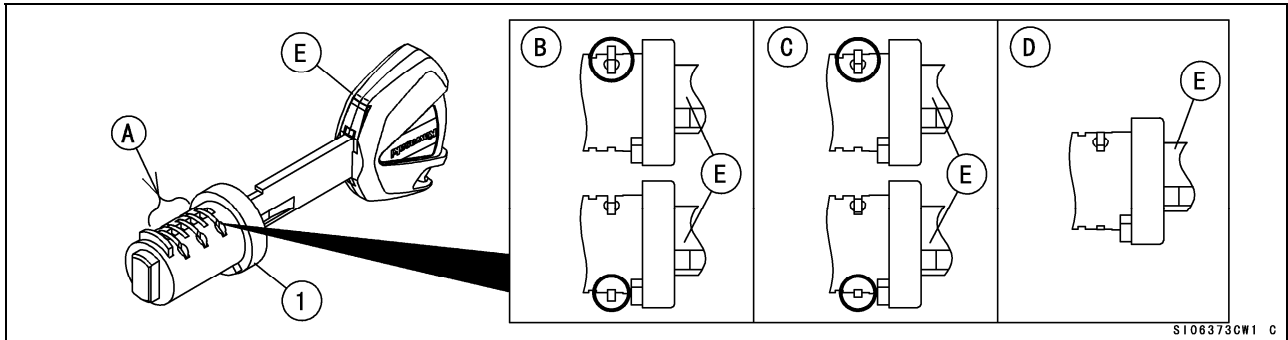

Step 4

- While lightly holding the tumblers in the rotor, remove the ignition key.

NOTE

○ If the tumblers are not held in place the tumblers or springs may become dislodged.

- Replace any projecting tumbler(s) with tumbler(s) from another bag and repeat steps 2, 3, and 4 again until all tumblers are level with the rotor.

Step 5

- Insert the key again as described in “Step 2” and make sure that all the tumblers [A] are level with the rotor. The stopper tumbler [B] should be projecting as shown. Ignition Key [C]

NOTE

○ Do not attempt to install the rotor into the helmet lock if the tumblers are not level. If the tumblers are not level the lock may become stuck when fitted to the helmet lock.

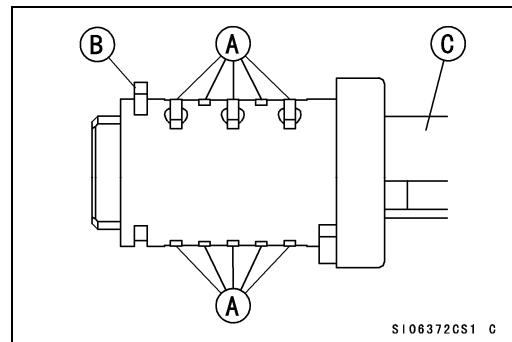

Step 6

- Pull out the ignition key a little from the rotor [A].
- To insert the rotor into the helmet lock [B]. Align the stopper tumbler [C] with the edge [D] of helmet lock. Push in the ignition key and turn clockwise gently.

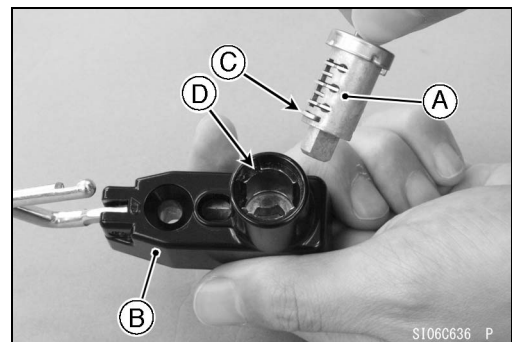

- Align the tumblers [A] and groove [B] of helmet lock.
- Carefully press the rotor in. You will hear a click when it is fully seated.
- Remove the ignition key.
- After installing the rotor, make sure that the lock operates correctly and when removing the ignition key the rotor is secure in the helmet lock.

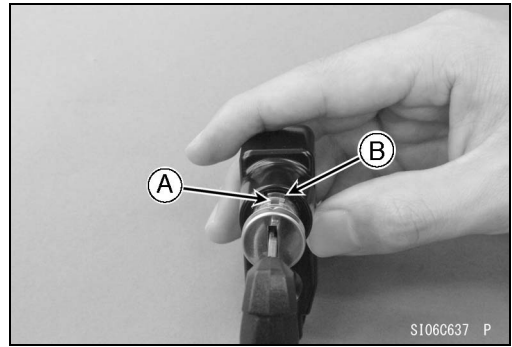

Assembly Procedure (Helmet Lock)

- Remove the left middle fairing (Refer to the Service Manual).
- Using a cleaning fluid, clean off any oil or dirt on the hatching area [A] of the bracket, and dry them with a clean cloth.

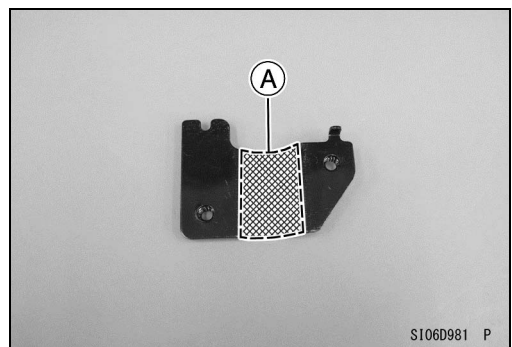

- Stick the pad [3] to the bracket [2] as shown.

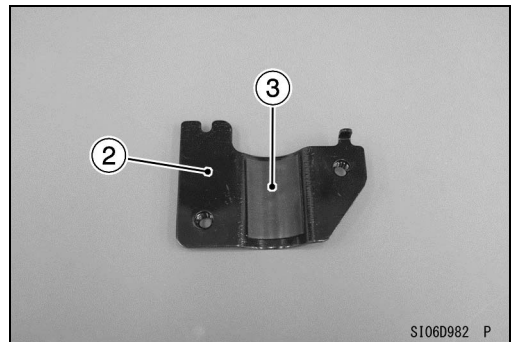

- Install the bracket to the frame so that the projection [A] of the bracket fits the frame hole [B].
- Tighten the bolt [4] securely.

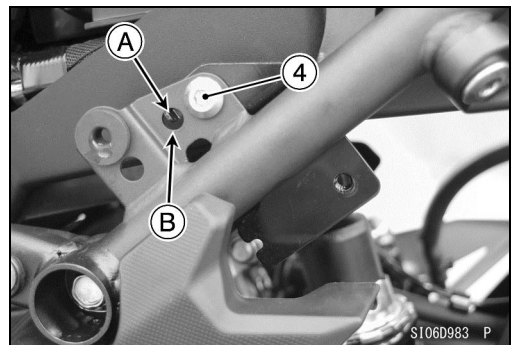

- Install the helmet lock [1].
- Fit the projection [A] of the helmet lock to the slit [B] of the bracket [2].

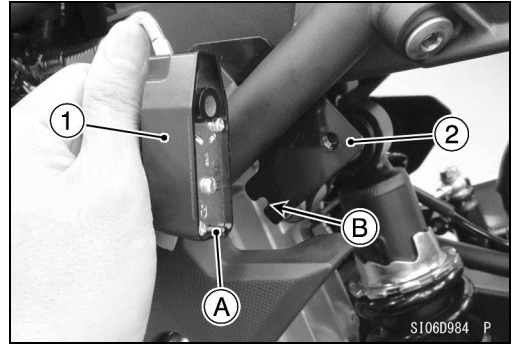

- Tighten the screw [3].
- Install the removed parts (Refer to the Service Manual).

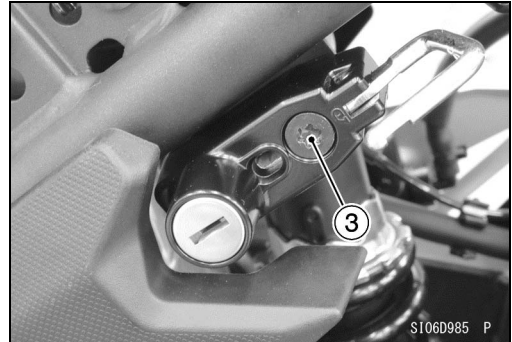

Basic Torque for General Fasteners

The table below, relating tightening torque to thread diameter, lists the basic torque for the bolts and nuts. Use this table for only the bolts and nuts which do not require a specific torque value. All of the values are for use with dry solvent-cleaned threads.

Threads dia. (mm)	Torque		
	N·m	kgf·m	ft·lb
5	3.4 ~ 4.9	0.35 ~ 0.50	30 ~ 43 in·lb
6	5.9 ~ 7.8	0.60 ~ 0.80	52 ~ 69 in·lb
8	14 ~ 19	1.4 ~ 1.9	10 ~ 13.5
10	25 ~ 34	2.6 ~ 3.5	19 ~ 25
12	44 ~ 61	4.5 ~ 6.2	33 ~ 45
14	73 ~ 98	7.4 ~ 10.0	54 ~ 72
16	115 ~ 155	11.5 ~ 16.0	83 ~ 115
18	165 ~ 225	17.0 ~ 23.0	125 ~ 165
20	225 ~ 325	23.0 ~ 33.0	165 ~ 240

Check tightness of all fasteners in regular interval. Retighten loose fasteners.