

Assembly Instructions

Model:	ZR900C
Description:	Front Fork Top Plug
Part Number:	99994-1019/1108
Flat Rate Time(Hr):	0.8

Before you begin, read through these instructions and check that all parts are present. Please note that Kawasaki cannot assume any responsibility for damage resulting from incorrect installation.

Kawasaki recommends that all genuine accessories should be fitted by an authorized Kawasaki dealer.

The following symbols indicate the information for proper installation and operation in this instruction.

- Indicates a procedural step or work to be done.
- Indicates a procedural sub-step or how to do the work of the procedural step it follows. It also precedes the text of a NOTE.
- ★ Indicates a conditional step or what action to take based on the results of the test or inspection in the procedural step or sub-step it follows.

Refer to the Service Manual (P/No.: 99924-1537-01) for detailed procedures.

Parts List				
No.	Component Name	Part No.	Qty	Remark
1	Front Fork Top Plug *1	11065-0992	2	Black
		11065-1282		Gold
2	O-ring	92055-0145	2	

*1: The front fork top plug has different color depending on the part number.



S106D922 P

Installation Instructions

- Remove the following parts (Refer to the Service Manual).
 - Front Wheel
 - Front Fender
 - Front Fork
 - Front Fork Top Plug
- Check the distance between the bottom end [A] of the top plug and rebound damping adjuster [B] with a pair of vernier caliper.
 - 18 mm (0.71 in.) [C]
- ★ If necessary, adjust the distance by turning the rebound damping adjuster.

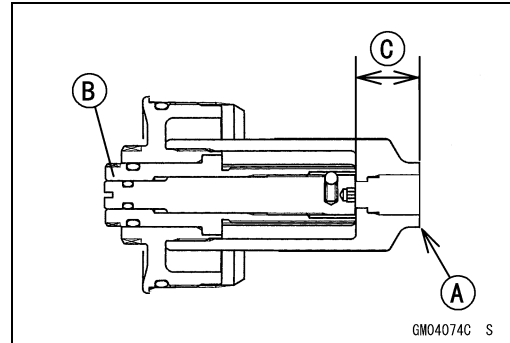

- Replace the O-ring [2] with a new one and install it to the top plug [1].
- Apply grease to the new O-ring.
- Install the top plug on the piston rod, and screw it.
- Holding the top plug with a wrench, tighten the piston rod nut [A] against the top plug.
- Place a plastic bag over the top plug to protect the top plug.

Torque – Piston Rod Nuts: 15 N·m (1.5 kgf·m, 11 ft·lb)

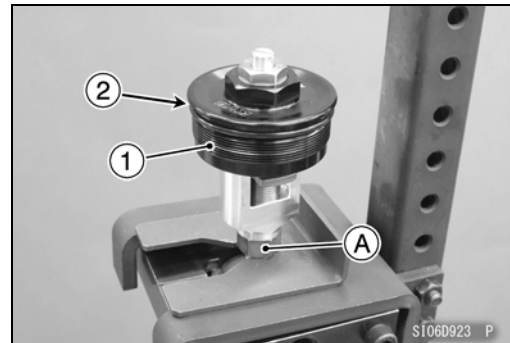

- Remove the fork spring stopper.
- Align the stoppers [A] of the top plug with the grooves [B] of the clamp, and lower the jack.
- Remove the front fork from the fork spring compressor.

Special Tool – Fork Spring Compressor: 57001-1771

- Raise the outer tube and tighten the top plug temporarily.
- Apply the final tightening after installing the front fork to the vehicle.

Torque – Front Fork Top Plug: 22.5 N·m (2.29 kgf·m, 16.6 ft·lb)

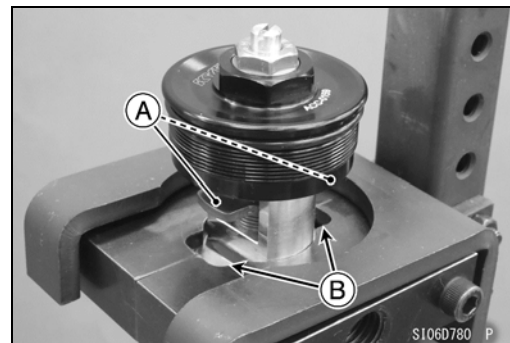

- Install the following parts (Refer to the Service Manual).
 - Front Fork
 - Front Fender
 - Front Wheel
- Adjust the front fork settings (Refer to the Service Manual).
 - Spring Preload
 - Rebound Damping Force
 - Compression Damping Force (Right Side Only)

Check tightness of all fasteners in regular interval. Retighten loose fasteners.