

Assembly Instructions

Model:	ZR1000K/L
Description:	Helmet Lock
Part Number:	99994-1436
Flat Rate Time(Hr):	0.4

Before you begin, read through these instructions and check that all parts are present. Please note that Kawasaki cannot assume any responsibility for damage resulting from incorrect installation.

Kawasaki recommends that all genuine accessories should be fitted by an authorized Kawasaki dealer.

The following symbols indicate the information for proper installation and operation in this instruction.

NOTE : NOTE indicates information that may help or guide you in the operation or service of the vehicle.

● Indicates a procedural step or work to be done.

○ Indicates a procedural sub-step or how to do the work of the procedural step it follows. It also precedes the text of a NOTE.

Refer to the Service Manual (P/No.: 99830-0034-04 or 99832-0067-04) for detailed procedures.

Parts List				
No.	Component Name	Part No.	Qty	Remark
1	Helmet Lock	27016-0091	1	
2	Screw (with a Non-permanent Locking Agent)	92172-1378	1	
3	Bracket	11057-3791	1	
4	Bolt	130CB0612	1	L = 12 mm
5	Bolt	130CB0625	1	L = 25 mm
6	Collar	92027-1941	1	
7	Bolt	92154-0774	1	

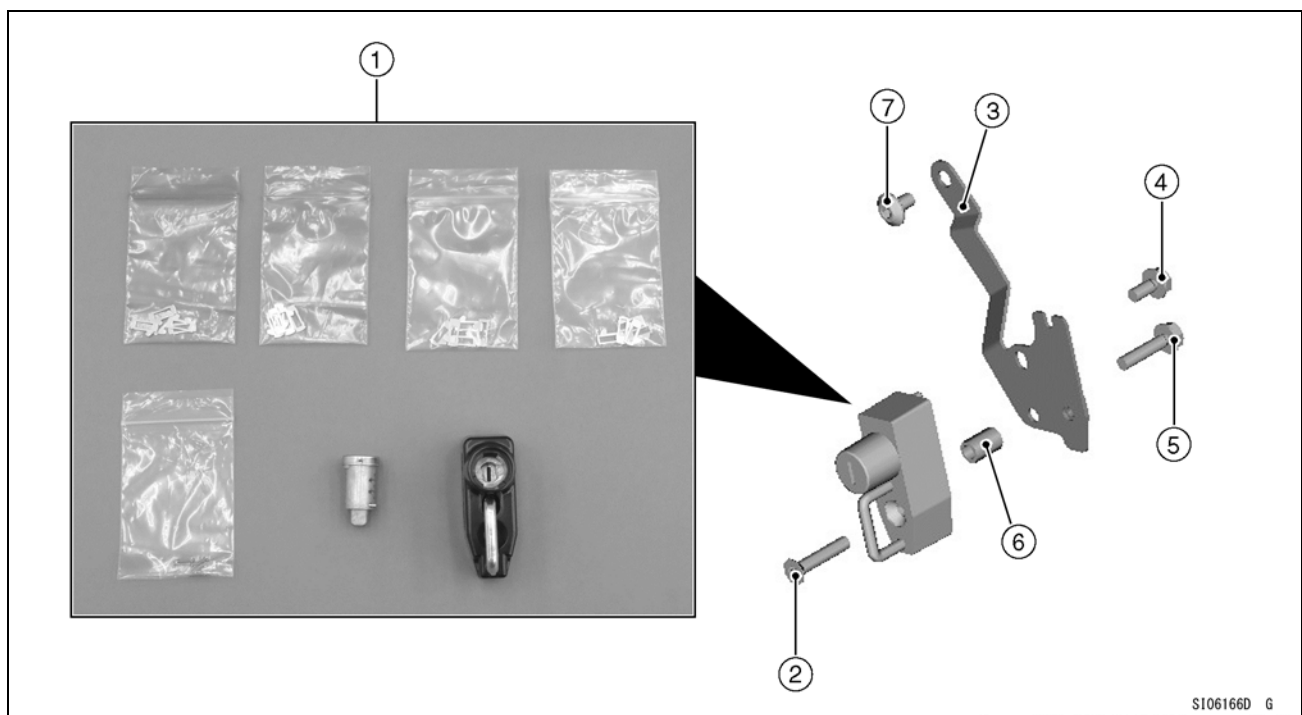

Installation Instructions

Assembly Procedure (One Key System)

- Using a combination of tumblers allows the lock rotor to be assembled to fit the existing ignition key.
- The four kinds of tumblers are a different length [A] to each other as shown.

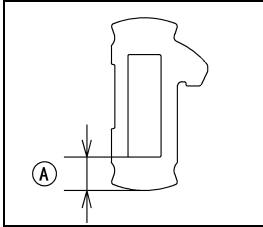

Tumbler #1: 2.5 mm (0.098 in.)

Tumbler #2: 3.0 mm (0.12 in.)

Tumbler #3: 3.5 mm (0.14 in.)

Tumbler #4: 4.0 mm (0.16 in.)

- The tumblers are separated into 4 plastic bags by different colors. Keep them in the bags until needed to prevent from being mixed up.

Step 1

- Install 5 springs [A] and 5 tumblers #1 [B] from a bag to the grooves [C] of the rotor [D]. Press each tumbler into its groove until it fully seats.

NOTE

- *The projection of the tumbler should sit over the spring.*

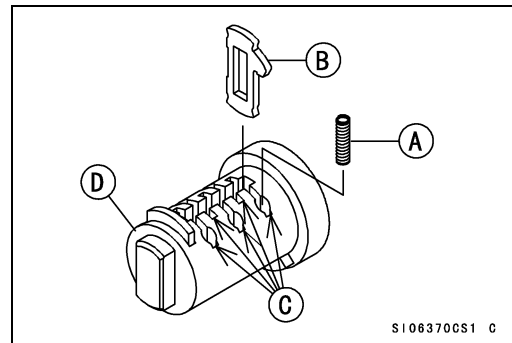

Step 2

- Lightly hold the tumblers [A] in the rotor [B] and insert the ignition key [C].

NOTE

- *If the tumblers are not held in place the tumblers or springs may become dislodged.*

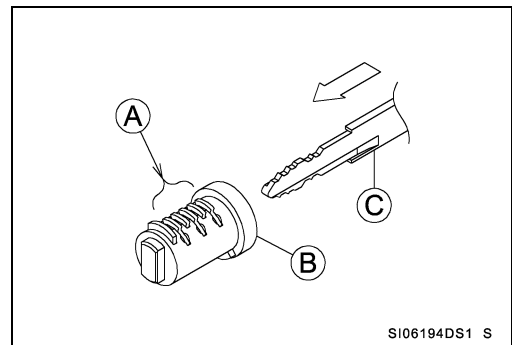

Step 3

- If the tumbler [A] is the correct one for the cut of the key, it will sit level with the rotor [1] once the ignition key [E] is inserted.
Incorrect: [B] Projecting high (upper or lower of rotor)
Incorrect: [C] Projecting low (upper or lower of rotor)
Correct: [D] Level with the rotor
- If any of the tumblers project out of the rotor, go to "Step 4."
- If all tumblers sit flush with the rotor it is correct. Go to "Step 5."

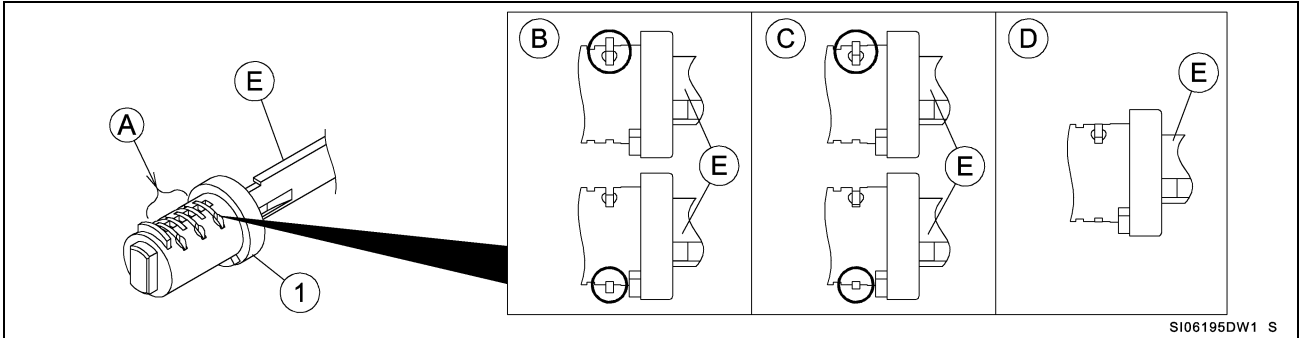

Step 4

- While lightly holding the tumblers in the rotor, remove the ignition key.

NOTE

○ If the tumblers are not held in place the tumblers or springs may become dislodged.

- Replace any projecting tumbler(s) with tumbler(s) from another bag and repeat steps 2, 3, and 4 again until all tumblers are level with the rotor.

Step 5

- Insert the key again as described in "Step 2" and make sure that all the tumblers [A] are level with the rotor. The stopper tumbler [B] should be projecting as shown.
Ignition Key [C]

NOTE

○ Do not attempt to install the rotor into the helmet lock if the tumblers are not level. If the tumblers are not level the lock may become stuck when fitted to the helmet lock.

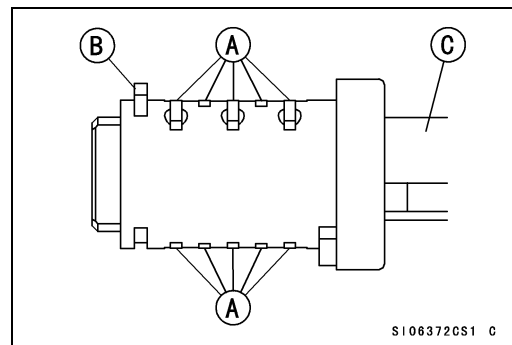

Step 6

- Pull out the ignition key a little from the rotor [A].
- To insert the rotor into the helmet lock [B]. Align the stopper tumbler [C] with the edge [D] of helmet lock. Push in the ignition key and turn clockwise gently.

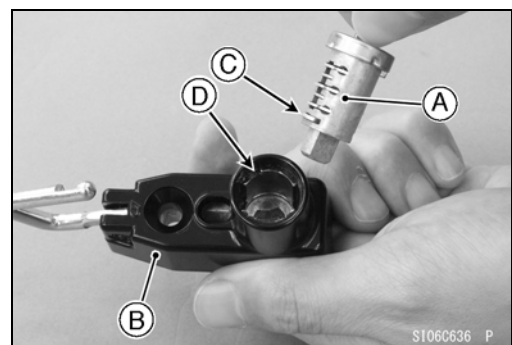

- Align the tumblers [A] and groove [B] of helmet lock.
- Carefully press the rotor in. You will hear a click when it is fully seated.
- Remove the ignition key.
- After installing the rotor, make sure that the lock operates correctly and when removing the ignition key the rotor is secure in the helmet lock.

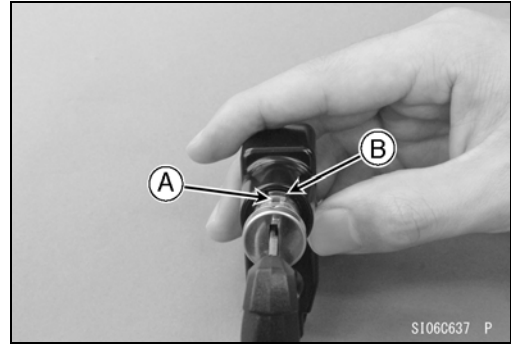

Assembly Procedure (Helmet Lock)

- Remove the following parts (Refer to the Service Manual).
 - Rear Seat
 - Front Seat
 - Left Front Seat Cover
- Install the bracket [3].
- Tighten the bolt [7] temporarily.

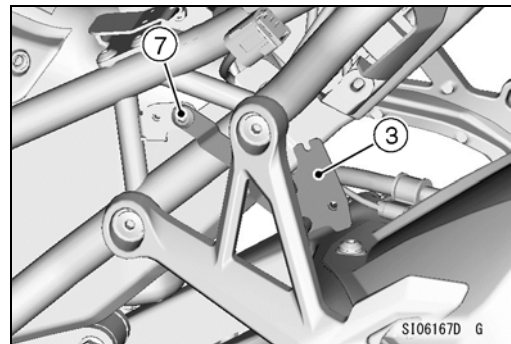

- Install:
 - Bolt [4]
 - Collar [6]
 - Bolt [5]
- Tighten the bolts [4] [5] [7].

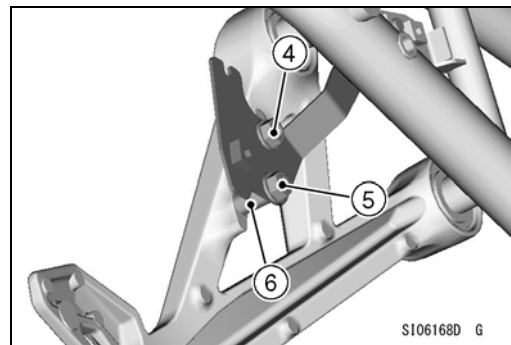

- Fit the projection [A] of the helmet lock [1] to the slit [B] of the bracket [3].
- Tighten the screw [2].
- Install the removed parts (Refer to the Service Manual).

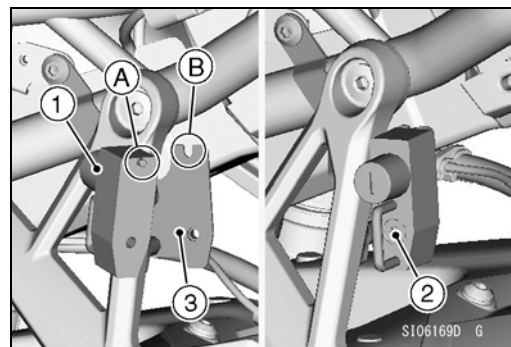

Basic Torque for General Fasteners

The tables below, relating tightening torque to thread diameter, lists the basic torque for the bolts, nuts and screws. Use these tables for the bolts, nuts and screws which are not specified the tightening torque particularly on the previous pages. All of the values are for use with dry solvent-cleaned threads.

For Bolts and Nuts

Threads dia. (mm)	Torque		
	N·m	kgf·m	ft·lb
5	4.5	0.46	40 in·lb
6	8.0	0.82	71 in·lb
8	20	2.0	15
10	35	3.6	26
12	60	6.1	44

For Screws, Plastic Part Tightening Portions and Plastic Washer Tightening Portions

Threads dia. (mm)	Torque		
	N·m	kgf·m	ft·lb
4	1.2	0.12	11 in·lb
5	3.0	0.31	27 in·lb
6	4.0	0.41	35 in·lb

For Self-Tapping Screws

Threads dia. (mm)	Torque		
	N·m	kgf·m	ft·lb
All	1.2	0.12	11 in·lb

For Wellnuts

Threads dia. (mm)	Torque		
	N·m	kgf·m	ft·lb
4	0.2	0.02	1.8 in·lb
5	0.5	0.05	4.4 in·lb
6	1.0	0.10	8.9 in·lb

Check tightness of all fasteners in regular interval. Retighten loose fasteners.